

1

PRACTICE PAPER

[Time Allowed: 90 Minutes]

[Maximum Marks: 40]

General Instructions:

- All Questions are compulsory.
- Each Question carries 1 mark.

Multiple Choice Questions

1. If α, β, γ are the zeroes of the polynomial $2x^3 + x^2 - 13x + 6$, then the value of $\alpha\beta\gamma$ is

- (a) 3 (b) -3 (c) $-\frac{1}{2}$ (d) $-\frac{13}{2}$

Ans. (b)

2. A quadratic polynomial whose one zero is 6 and sum of the zeroes is 0, is

- (a) $x^2 - 6x + 2$ (b) $x^2 - 36$ (c) $x^2 - 6$ (d) $x^2 - 3$

Ans. (b)

3. If α, β, γ be the zeroes of the polynomial $p(x)$ such that $(\alpha + \beta + \gamma) = 3$, $\alpha\beta + \beta\gamma + \gamma\alpha = -10$ and $\alpha\beta\gamma = -24$, then $p(x)$ is

- (a) $x^3 + 3x^2 - 10x + 24$ (b) $x^3 + 3x^2 + 10x - 24$
(c) $x^3 - 3x^2 - 10x + 24$ (d) None of these

Ans. (c)

4. A quadratic polynomial whose one zero is 5 and product of zeroes is 0, is

- (a) $x^2 - 5$ (b) $x^2 - 5x$ (c) $5x^2 + 1$ (d) $x^2 + 5x$

Ans. (b)

5. The pair of linear equations $2x + 3y = 5$ and $4x + 6y = 10$ is

- (a) inconsistent (b) consistent (c) dependent consistent (d) none of these

Ans. (c)

6. Match the Column:

(1)	$2x + 3y = 40$ $6x + 5y = 10$	(A)	Coincident lines
(2)	$2x + 3y = 40$ $6x + 9y = 50$	(B)	Intersecting lines
(3)	$2x + 3y = 10$ $4x + 6y = 20$	(C)	Parallel lines

- (a) 1 – A, 2 – B, 3 – C (b) 1 – B, 2 – A, 3 – C
 (c) 1 – B, 2 – C, 3 – A (d) 1 – C, 2 – A, 3 – B.

Ans. (c)

7. If $ax + by = c$ and $lx + my = n$ has unique solution then the relation between the coefficient will be:

- (a) $am \neq lb$ (b) $am = lb$ (c) $ab = lm$ (d) $ab \neq lm$

Ans. (a)

8. The pair of equations $x = 4$ and $y = 3$ graphically represents lines which are

- (a) parallel (b) intersecting at (3, 4)
 (c) coincident (d) intersecting at (4, 3)

Ans. (d)

9. $a_1x + b_1y + c_1 = 0$ and $a_2x + b_2y + c_2 = 0$, where $a_1, b_1, c_1, a_2, b_2, c_2$ are all real numbers and $a_1^2 + b_1^2 \neq 0, a_2^2 + b_2^2 \neq 0$, is called a

- (a) family of two different straight lines
 (b) family of two coincident lines
 (c) pair of linear equations in two variables
 (d) none of these

Ans. (c)

10. If $\Delta ABC \sim \Delta EDF$ and ΔABC is not similar to ΔDEF , then which of the following is not true?

- (a) $BC \cdot EF = AC \cdot FD$ (b) $AB \cdot EF = AC \cdot DE$
 (c) $BC \cdot DE = AB \cdot EF$ (d) $BC \cdot DE = AB \cdot FD$

Ans. (d)

11. If A and B are the points $(-3, 4)$ and $(2, 1)$ respectively, then the coordinates of the point on AB produced such that $AC = 2BC$ are

- (a) (2, 4) (b) (3, 7) (c) (7, -2) (d) none of these

Ans. (c)

12. If triangle PQR is a right triangle right angled at Q, then PQ is known as

- (a) side adjacent to angle P (b) hypotenuse
 (c) side opposite to angle P (d) side adjacent to angle R

Ans. (a)

13. Match the Columns:

1. $\frac{\text{Hypotenuse}}{\text{Side adjacent to angle } \theta}$	(A) cosec θ
2. $\frac{\text{Side adjacent to angle } \theta}{\text{Side opposite to angle } \theta}$	(B) sec θ
3. $\frac{\text{Hypotenuse}}{\text{Side opposite to angle } \theta}$	(C) tan θ
	(D) cot θ
	(E) sin θ

(a) 1 – A, 2 – C, 3 – B

(b) 1 – C, 2 – A, 3 – D

(c) 1 – B, 2 – A, 3 – E

(d) 1 – B, 2 – D, 3 – A

Ans. (d)

14. If $3 \cot \theta = 2$, then the value of $\tan \theta$

(a) $\frac{2}{3}$

(b) $\frac{3}{2}$

(c) $\frac{3}{\sqrt{13}}$

(d) $\frac{2}{\sqrt{13}}$

Ans. (b)

15. The value of $\cos 0^\circ \cdot \cos 1^\circ \cdot \cos 2^\circ \dots \cos 90^\circ =$

(a) 1

(b) 2

(c) 3

(d) none of these

Ans. (d)

16. If $\sin \theta$ and $\cos \theta$ are the roots of the equation $ax^2 - bx + c = 0$, then a, b, c satisfy the relation

(a) $b^2 - a^2 = 2ac$

(b) $a^2 - b^2 = 2ac$

(c) $a^2 + b^2 = c^2$

(d) $a^2 + b^2 = 2ac$

Ans. (a)

17. If the circumference and the area of a circle are numerically equal, then the radius of the circle is

(a) 2 units

(b) π units

(c) 4 units

(d) 7 units

Ans. (a)

18. A wheel makes 1000 revolutions in covering a distance of 0.88 km. The radius of the wheel is

(a) 7 cm

(b) 14 cm

(c) 21 cm

(d) 28 cm

Ans. (a)

19. The radii of two circles are 4 cm and 3 cm respectively. The diameter of the circle having area equal to the sum of the areas of the two circles (in cm) is

(a) 5

(b) 7

(c) 10

(d) 14

Ans. (c)

20. Which of the following cannot be the probability of an event?

- (a) 1.5 (b) $\frac{3}{5}$ (c) 25% (d) 0.3

Ans. (a)

21. An event is very unlikely to happen. Its probability is closest to

- (a) 0.0001 (b) 0.001 (c) 0.01 (d) 0.1

Ans. (c)

22. HCF of $5^2 \times 3^2$ and $3^5 \times 5^3$ is:

- (a) $5^3 \times 3^5$ (b) 5×3^3 (c) $5^3 \times 3^2$ (d) $5^2 \times 3^2$

Ans. (d)

Assertion-Reasoning Type MCQs

Direction: In the following question no. 23 to 25, a statement of assertion (A) is followed by a statement of reason (R). Mark the correct choice as:

- (a) Both assertion (A) and reason (R) are true and reason (R) is the correct explanation of assertion (A).
(b) Both assertion (A) and reason (R) are true but reason (R) is not the correct explanation of assertion (A).
(c) Assertion (A) is true but reason (R) is false.
(d) Assertion (A) is false but reason (R) is true.

23. **Assertion (A):** If one zero of the polynomial $p(x) = (k^2 + 4)x^2 + 9x + 4k$ is the reciprocal of the other zero then $k = 2$

Reason (R): If $(x - \alpha)$ is a factor of the polynomial $p(x)$, then α is a zero of $p(x)$.

Ans. (a)

24. Assertion (A): If a wire of length 22 cm is bent in the shape of a circle, then area of the circle so formed is 40 cm^2 .

Reason (R): Circumference of the circle = length of the wire.

Ans. (d)

25. Assertion (A): Cards numbered 1, 2, 3..., 15 are put in a box and mixed thoroughly one card is then drawn at random. The probability of drawing an even number is $\frac{1}{2}$.

Reason (R): For any event E, we have $0 \leq P(E) \leq 1$

Ans. (d)

Case Based MCQs

I. Ravish runs a book shop at school of Math, Gurgaon. He received 480 chemistry books, 192 physics books and 672 Mathematics books of class XI.

He wishes to average these books in minimum numbers of stacks such that each stack consists of the books on only one subject and the number of books in each stack is the same.



26. Find the number of books in each stack.

- (a) 26 (b) 48 (c) 24 (d) 56

Ans. (b)

27. Number of stacks of Mathematics books are

- (a) 24 (b) 14 (c) 60 (d) 80

Ans. (b)

28. Minimum number of stacks of all the books are

- (a) 24 (b) 25 (c) 27 (d) 28

Ans. (d)

29. Difference in number of stacks of Mathematics books and sum of stacks of Physics and Chemistry books is

- (a) 4 (b) 10 (c) 8 (d) 0

Ans. (d)

30. If the thickness of each book of physics is 2.5 cm then height of each stack is

- (a) 1.4 m (b) 1.3 m (c) 1.2 m (d) 1 m

Ans. (c)

II. Vijay is trying to find the average height of a tower near his house. He is using the properties of similar triangles. The height of Vijay's house is 20 m when Vijay's house casts a shadow 10 m long on the ground. At the same time, the tower casts a shadow 50 m long on the ground and the house of Ajay casts 20 m shadow on the ground.

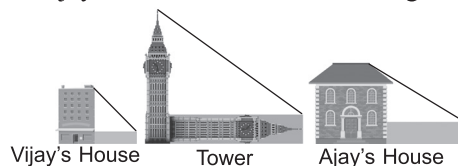

31. What is the height of the tower?

- (a) 20 m (b) 50 m (c) 100 m (d) 200 m

Ans. (c) 100 m

32. What will be the length of the shadow of the tower when Vijay's house casts a shadow of 12 m?

- (a) 75 m (b) 50 m (c) 45 m (d) 60 m

Ans. (d)

33. What is the height of Ajay's house?

- (a) 30 m (b) 40m (c) 50 m (d) 20m

Ans. (b)

34. When the tower casts a shadow of 40 m, same time what will be the length of the shadow of Ajay's house?

- (a) 16 m (b) 32 m (c) 20 m (d) 8 m

Ans. (a)

35. When the tower casts a shadow of 40 m, same time what will be the length of the shadow of Vijay's house?

- (a) 15 m (b) 32 (c) 16 m (d) 8 m

Ans. (d)

III. In order to conduct Sports Day activities in your School, lines have been drawn with chalk powder at a distance of 1 m each, in a rectangular shaped ground ABCD, 100 flowerpots have been placed at a distance of 1 m from each other along AD, as shown in given figure below. Niharika runs $\frac{1}{4}$ th the distance AD on the 2nd line and posts a green flag. Preet runs $\frac{1}{5}$ th distance AD on the eighth line and posts a red flag.

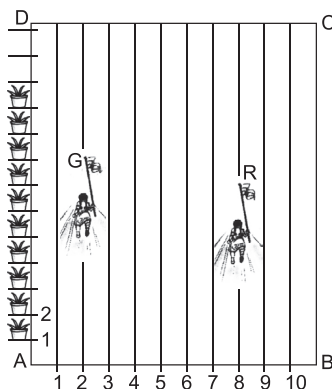

36. Find the position of green flag

- (a) (2, 25) (b) (2, 0.25) (c) (25, 2) (d) (0, -25)

Ans. (a)

37. Find the position of red flag

- (a) (8, 0) (b) (20, 8) (c) (8,20) (d) (8,0.2)

Ans. (c)

38. What is the distance between both the flags?

- (a) $\sqrt{41}$ (b) $\sqrt{11}$ (c) $\sqrt{61}$ (d) $\sqrt{51}$

Ans. (c)

39. If Rashmi has to post a blue flag exactly halfway between the line segment joining the two flags, where should she post her flag?

- (a) (5, 22.5) (b) (10, 22) (c) (2,8.5) (d) (2.5,20)

Ans. (a)

40. If Joy has to post a flag at one-fourth distance from green flag ,in the line segment join in the green and red flags, then where should he post his flag?

- (a) (3.5, 24) (b) (0.5, 12.5) (c) (2.25, 8.5) (d) (25, 20)

Ans. (a)

2

PRACTICE PAPER

[Time Allowed: 90 Minutes]

[Maximum Marks: 40]

General Instructions:

- All Questions are compulsory.
- Each Question carries 1 mark.

Multiple Choice Questions

1. If two positive integers a and b are written as $a = x^3y^2$ and $b = xy^3$, where x, y are prime numbers, then HCF(a, b) is
(a) xy (b) xy^2 (c) x^3y^3 (d) x^2y^2
2. The ratio between the LCM and HCF of 5, 15, 20 is:
(a) 9 : 1 (b) 4 : 3 (c) 11 : 1 (d) 12 : 1
3. If $A = 2n + 13$, $B = n + 7$, where n is a natural number, then HCF of A and B is:
(a) 2 (b) 1 (c) 3 (d) 4
4. The HCF and the LCM of 12, 21, 15 respectively are
(a) 3, 140 (b) 12, 420 (c) 3, 420 (d) 420, 3
5. The total number of factors of a prime number is
(a) 1 (b) 0 (c) 2 (d) 3
6. In the given figure, $\frac{AD}{BD} = \frac{AE}{EC}$ and $\angle ADE = 70^\circ$, $\angle BAC = 50^\circ$, then angle $\angle BCA =$

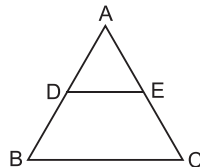

- (a) 70° (b) 50° (c) 80° (d) 60°

7. Which pair of the given quadrilaterals is similar?

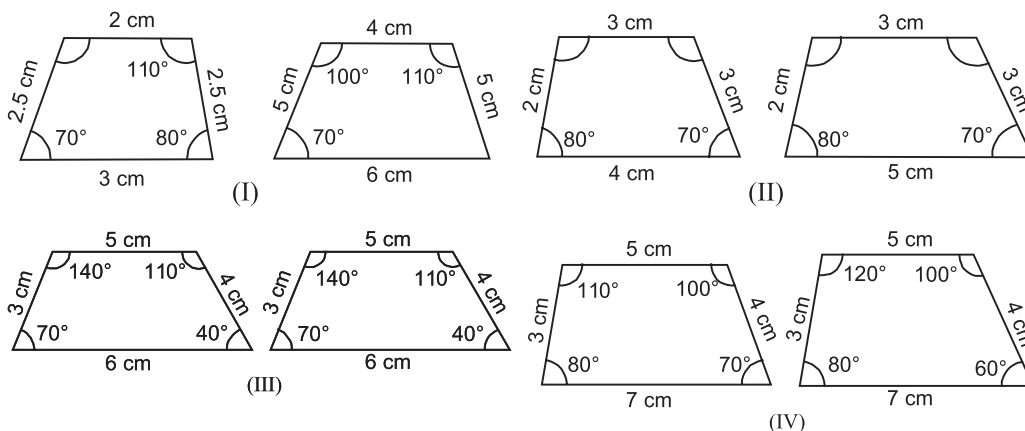

- (a) I (b) II (c) III (d) IV

8. If in two triangles ABC and PQR,

$$\frac{AB}{QR} = \frac{BC}{PR} = \frac{CA}{PQ}, \text{ then}$$

- (a) $\Delta PQR \sim \Delta CAB$ (b) $\Delta PQR \sim \Delta ABC$
 (c) $\Delta CBA \sim \Delta PQR$ (d) $\Delta BCA \sim \Delta PQR$

9. If in two triangles DEF and PQR, $\angle D = \angle Q$ and $\angle R = \angle E$, then which of the following is not true?

(a) $\frac{EF}{PR} = \frac{DF}{PQ}$ (b) $\frac{DF}{PQ} = \frac{EF}{RP}$ (c) $\frac{DE}{QR} = \frac{DF}{PQ}$ (d) $\frac{EF}{RP} = \frac{DE}{QR}$

10. If in two right triangles, hypotenuse and one side of one triangle are proportional to the hypotenuse and one side of the other triangle, then the two triangles are similar. This may be referred to as the

- (a) AAA similarity criterion (b) ASS similarity criterion
 (c) SAS similarity criterion (d) RHS similarity criterion

11. A triangle with vertices (4, 0), (-1, -1) and (3, 5) is a/an

- (a) equilateral triangle (b) right-angled triangle
 (c) isosceles right-angled triangle (d) none of these

12. If the distance between the points(4, p) and (1, 0) is 5 units, then the value of p is

- (a) 4 only (b) ± 4 (c) -4 only (d) 0

13. AOBC is a rectangle whose three vertices are A(0, 3), O(0, 0) and B(5, 0). The length of its diagonal is
 (a) 5 (b) 3 (c) $\sqrt{34}$ (d) 4
14. If the distance between the points (8, p) and (4, 3) is 5 units, then value of p is
 (a) 6 (b) 0 (c) none of these (d) both (a) and (b)
15. If three points (0, 0), (3, $\sqrt{3}$) and (3, k) form an equilateral triangle, then $k =$
 (a) 2 (b) -3 (c) $-\sqrt{3}$ (d) $-\sqrt{2}$
16. If the circumference of a circle and the perimeter of a square are equal, then
 (a) area of the circle = area of the square
 (b) area of the circle > area of the square
 (c) area of the circle < area of the square
 (d) nothing definite can be said about the relation between the areas of the circle and square.
17. Area of the largest triangle that can be inscribed in a semi-circle of radius r units is
 (a) r^2 sq. units (b) $\frac{1}{2} r^2$ sq. units (c) $2 r^2$ sq. units (d) $\sqrt{2} r^2$ sq. units
18. In the given figure, three sectors of a circle of radius 7 cm, making angles of 60° , 80° and 40° at the centre are shaded. The area of the shaded region (in cm^2) is $\left[\text{Using } \pi = \frac{22}{7} \right]$

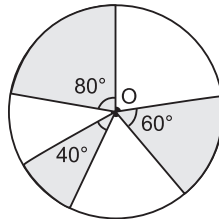

- (a) 77 (b) 154 (c) 44 (d) 22
19. If π is taken as $\frac{22}{7}$, the distance (in metres) covered by a wheel of diameter 35 cm, in one revolution, is
 (a) 2.2 (b) 1.1 (c) 9.625 (d) 96.25
20. If an event cannot occur, then its probability is
 (a) 1 (b) $\frac{3}{4}$ (c) $\frac{1}{2}$ (d) 0

21. A coin is tossed twice. The probability of getting both heads is
 (a) $\frac{1}{2}$ (b) $\frac{1}{3}$ (c) $\frac{1}{4}$ (d) 1

22. Match the columns:

(1) Probability of sure event	(A) $\frac{1}{2}$
(2) Probability of impossible event	(B) 0
(3) A and B are complementary events	(C) 1
	(D) $P(B) = 1 - P(A)$
	(E) $P(A) = P(B)$

- (a) (1) \rightarrow (A), (2) \rightarrow (B), (3) \rightarrow (C)
 (b) (1) \rightarrow (B), (2) \rightarrow (A), (3) \rightarrow (C)
 (c) (1) \rightarrow (C), (2) \rightarrow (B), (3) \rightarrow (E)
 (d) (1) \rightarrow (C), (2) \rightarrow (B), (3) \rightarrow (D)

Assertion-Reasoning Type MCQs

Direction: In the following question no. 23 to 25, a statement of assertion (A) is followed by a statement of reason (R). Mark the correct choice as:

- (a) Both assertion (A) and reason (R) are true and reason (R) is the correct explanation of assertion (A).
 (b) Both assertion (A) and reason (R) are true but reason (R) is not the correct explanation of assertion (A).
 (c) Assertion (A) is true but reason (R) is false.
 (d) Assertion (A) is false but reason (R) is true.

23. **Assertion (A):** $\frac{124}{2500}$ is a terminating decimal.

Reason (R): The rational number $\frac{p}{q}$ is a terminating decimal, if $q = (2^m \times 5^n)$ for some whole numbers m and n .

24. **Assertion (A):** If in a ΔABC , a line $DE \parallel BC$, intersects AB in D and AC in E , then $\frac{AB}{AD} = \frac{AC}{AE}$

Reason (R): If a line is drawn parallel to one side of a triangle intersecting the other two sides, then the other two sides are divided in the same ratio.

25. **Assertion (A):** The point $(0, 6)$ lies on y -axis.

Reason (R): The x -coordinate on the point on y -axis is zero.

Case Based MCQs

- I. The below picture are few natural examples of parabolic shape which is represented by a quadratic polynomial. A parabolic arch is an arch in the shape of a parabola. In structures, their curve represents an efficient method of load, and so can be found in bridges and in architecture in a variety of forms.

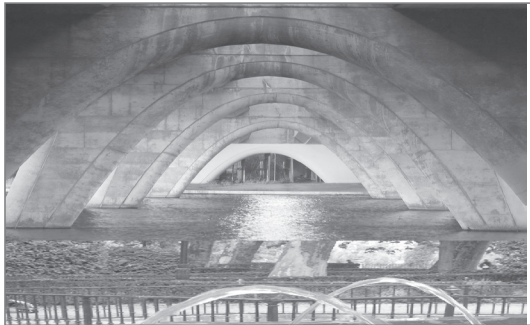

26. In the standard form of quadratic polynomial, $ax^2 + bx + c$, a , b and c are
- (a) All are real numbers.
 - (b) All are rational numbers.
 - (b) 'a' is a non zero real number and b and c are any real numbers.
 - (b) All are integers.
27. If the roots of the quadratic polynomial are equal, where the discriminant $D = b^2 - 4ac$, then
- (a) $D > 0$
 - (b) $D < 0$
 - (c) $D \geq 0$
 - (d) $D = 0$
28. If α and $\frac{1}{\alpha}$ are the zeroes of the quadratic polynomial $2x^2 - x + 8k$, then k is
- (a) 4
 - (b) $\frac{1}{4}$
 - (c) $-\frac{1}{4}$
 - (d) 2
29. The graph of $x^2 + 1 = 0$
- (a) Intersects the x -axis at two distinct points.
 - (b) Touches the x -axis at a point.
 - (c) Neither touches nor intersects the x -axis.
 - (d) Either touches or intersects the x -axis.

30. If the sum of the roots is $-p$ and product of the roots is $-\frac{1}{p}$, then the quadratic polynomial is

- (a) $k\left(-px^2 + \frac{x}{p} + 1\right)$ (b) $k\left(px^2 - \frac{x}{p} - 1\right)$
 (c) $k\left(x^2 + px - \frac{1}{p}\right)$ (d) $k\left(x^2 - px + \frac{1}{p}\right)$

II. An asana is a body posture, originally and still a general term for a sitting meditation pose, and later extended in hatha yoga and modern yoga as exercise, to any type of pose or position, adding reclining, standing, inverted, twisting, and balancing poses. In the figure, one can observe that poses can be related to representation of quadratic polynomial.



Trikonasana

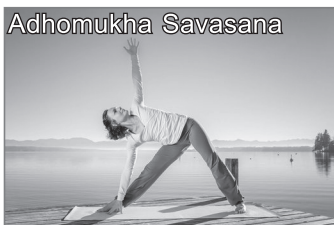

Adhomukha Savasana

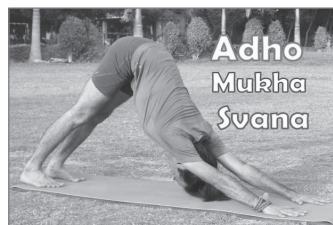

Adho
Mukha
Svana

31. The shape of the poses shown is

- (a) Spiral (b) Ellipse (c) Linear (d) Parabola

32. The graph of parabola opens downwards, if _____

- (a) $a \geq 0$ (b) $a = 0$ (c) $a < 0$ (d) $a > 0$

33. In the graph, how many zeroes are there for the polynomial?

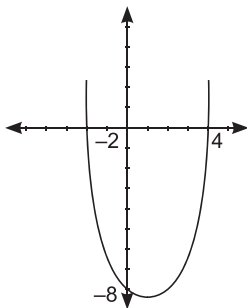

- (a) 0 (b) 1 (c) 2 (d) 3

34. The two zeroes in the above shown graph are

- (a) 2, 4 (b) -2, 4 (c) -8, 4 (d) 2, -8

35. The zeroes of the quadratic polynomial $4\sqrt{3}x^2 + 5x - 2\sqrt{3}$ are

- (a) $\frac{2}{\sqrt{3}}, \frac{\sqrt{3}}{4}$ (b) $-\frac{2}{\sqrt{3}}, \frac{\sqrt{3}}{4}$ (c) $\frac{2}{\sqrt{3}}, -\frac{\sqrt{3}}{4}$ (d) $-\frac{2}{\sqrt{3}}, -\frac{\sqrt{3}}{4}$

3

PRACTICE PAPER

[Time Allowed: 90 Minutes]

[Maximum Marks: 40]

General Instructions:

- All Questions are compulsory.
- Each Question carries 1 mark.

Multiple Choice Questions

1. Two equilateral triangles have the sides of lengths 34 and 85 respectively. The greatest length of tape that can measure the sides of both of them exactly is
(a) 34 (b) 17 (c) 51 (d) none of these
2. Find the greatest number of 5 digits, that will give us remainder of 5, when divided by 8 and 9 respectively.
(a) 99921 (b) 99931 (c) 99941 (d) 99951
3. What is the smallest number which when increased by 6 becomes divisible by 36, 63 and 108 ?
(a) 750 (b) 752 (c) 754 (d) 756
4. LCM of 5, 8, 12, 20 will not be a multiple of
(a) 5 (b) 3 (c) 9 (d) 2
5. Two natural numbers whose difference is 66 and the least common multiple is 360, are
(a) 120 and 54 (b) 90 and 24 (c) 180 and 114 (d) 130 and 64
6. A forester wants to plant 66 apple trees 88 banana trees and 110 mango trees in equal rows (in terms of number of trees). Also he wants to make distinct rows of trees (*i.e.*, only one type of trees in one row). The number of minimum rows required are
(a) 2 (b) 3 (c) 10 (d) 12

7. A polynomial of degree n has
 (a) only 1 zero (b) exactly n zeroes (c) atmost n zeroes (d) more than n zeroes
8. If $p(x) = ax^2 + bx + c$, then $\frac{c}{a}$ is equal to
 (a) 0 (b) 1
 (c) sum of zeroes (d) product of zeroes
9. The value of m so that $4x^2 - 6x - m$ is divisible by $x - 3$, is exact divisor of
 (a) 9 (b) 45 (c) 20 (d) 36
10. If one factor of $x^3 + 7kx^2 - 4kx + 12$ is $(x + 3)$, then the value of k is
 (a) 5 (b) $\frac{1}{5}$ (c) $\frac{-13}{17}$ (d) $\frac{-17}{13}$
11. In the given figure, $DE \parallel BC$. The value of EC is

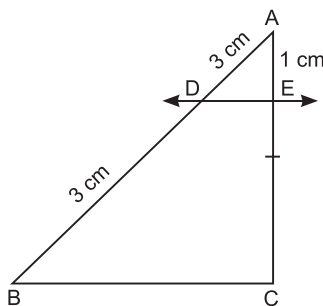

- (a) 1.5 cm (b) 3 cm (c) 2 cm (d) 1 cm
12. The pair of equations $y = 0$ and $y = -7$ has
 (a) one solution (b) two solutions
 (c) infinitely many solutions (d) no solution
13. The pair of equations $x = a$ and $y = b$ graphically represents lines which are
 (a) parallel (b) intersecting at (b, a)
 (c) coincident (d) intersecting at (a, b)
14. The value of k for which the system of equations $x + y - 4 = 0$ and $2x + ky = 3$, has no solution, is
 (a) -2 (b) $\neq 2$ (c) 3 (d) 2
15. A told B, 'when I was as old as you are now ,then your age was four years less than half of my present age. If the sum of the present ages of A and B is 61 years,what is B's present age? (in years)
 (a) 9 (b) 25 (c) 43 (d) 36

16. A toothed wheel of diameter 50 cm is attached to a smaller wheel of diameter 30 cm. How many revolutions will the smaller wheel make when the larger one makes 15 revolutions?
 (a) 23 (b) 24 (c) 25 (d) 26
17. The radius of a circle is 50 cm. If the radius is decreased by 50%, its area will be decreased by
 (a) 50% (b) 75% (c) 80% (d) 25%
18. The diameter of a wheel is 1.26 m. The distance travelled in 500 revolutions is
 (a) 2670 m (b) 2880 m (c) 1980 m (d) 1596 m
19. If the sum of the areas of two circles with radii R_1 and R_2 is equal to the area of a circle of radius R , then
 (a) $R_1 + R_2 = R$ (b) $R_1^2 + R_2^2 = R^2$
 (c) $R_1 + R_2 < R$ (d) $R_1^2 + R_2^2 < R^2$
20. The probability that a leap year should have at least 52 Tuesday is
 (a) $\frac{2}{7}$ (b) $\frac{3}{7}$ (c) 1 (d) $\frac{5}{7}$
21. A card is selected from a deck of 52 cards. The probability of its being a red face card is
 (a) $\frac{3}{26}$ (b) $\frac{3}{13}$ (c) $\frac{2}{13}$ (d) $\frac{1}{2}$
22. Which of the following cannot be the probability of an event?
 (a) $\frac{1}{3}$ (b) 0.1 (c) 3% (d) $\frac{17}{16}$

Assertion-Reasoning Type MCQs

Direction: In the following question no. 23 to 25, a statement of assertion (A) is followed by a statement of reason (R). Mark the correct choice as:

- (a) Both assertion (A) and reason (R) are true and reason (R) is the correct explanation of assertion (A).
- (b) Both assertion (A) and reason (R) are true but reason (R) is not the correct explanation of assertion (A).

(c) Assertion (A) is true but reason (R) is false.

(d) Assertion (A) is false but reason (R) is true.

23. **Assertion (A):** Two similar triangles are always congruent.

Reason (R): If the areas of two similar triangles are equal then the triangles are congruent.

24. **Assertion (A):** The value of y is 4, for which the distance between the points $P(2, -3)$ and $Q(0, y)$ is 10.

Reason (R): Distance between two given points $A(x_1, y_1)$ and $B(x_2, y_2)$ is 6,

$$AB = \sqrt{(x_2 - x_1)^2 + (y_2 - y_1)^2}$$

25. **Assertion (A):** If the system of equations $2x + 3y = 7$ and $2ax + (a + b)y = 28$ has one solution, then $2a - b = 0$

Reason (R): The system of equations $3x - 5y = 9$ and $6x - 10y = 8$ has infinitely many solution.

Case Based MCQs

I. Rohan wants to measure the distance of a pond during the visit to his native. He marks points A and B on the opposite edges of a pond as shown in the figure below. To find the distance between the points, he makes a right-angled triangle using rope connecting B with another point C are a distance of 12 m, connecting C to point D at a distance of 40 m from point C and the connecting D to the point A which is are a distance of 30 m from D such the $\angle ADC = 90^\circ$.

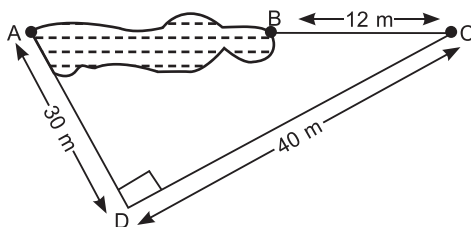

26. Which property of geometry will be used to find the distance AC?

(a) Similarity of triangles

(b) Thales Theorem

(c) Pythagoras Theorem

(d) Area of similar triangles

27. What is the distance AC?

- (a) 50 m (b) 12 m (c) 100 m (d) 70 m

28. Which of the following does not form a Pythagoras triplet?

- (a) (7,24,25) (b) (15,8,17) (c) (5,12,13) (d) (21,20,28)

29. Find the length AB?

- (a) 12 m (b) 38 m (c) 50 m (d) 100 m

30. Find the length of the rope used.

- (a) 120 m (b) 70 m (c) 82 m (d) 22 m

II. POSITION OF FLAGS

For annual day practice students of a class are standing in rows and columns. Four students Ashish, Bipin, Cintha and Damodar are holding flags. their position is shown as in the figure.

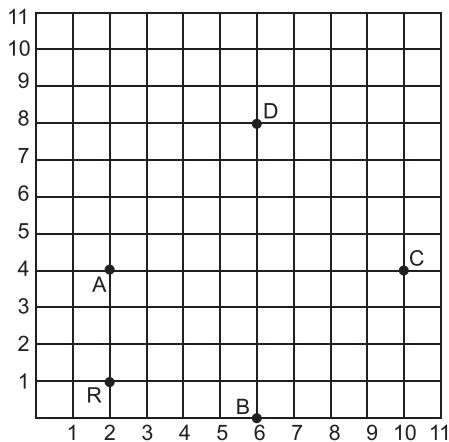

31. What are the coordinates of D?

- (a) (8, 6) (b) (6, 8) (c) (9, 6) (d) (6, 9)

32. What is the distance of A from D?

- (a) $3\sqrt{2}$ units (b) $4\sqrt{2}$ units
(c) 4 units (d) 6 units

33. Ram is positioned at R. He moves from R and take his position such that he is equidistant from A and C. What are the coordinates of Ram in its new position?
 (a) (4, 6) (b) (5, 6) (c) (6, 4) (d) (6, -5)
34. How much distance is covered by Ram to move to the new position?
 (a) 5 units (b) 6 units (c) 7 units (d) 8 units
35. Which of the following is not true?
 (a) $AB = BC$ (b) $AB = AD$ (c) $BD = AC$ (d) $AC = BC$

III. THREE FRIENDS

Three friends stand in such a way that they form a right angled $\triangle ABC$ as shown.

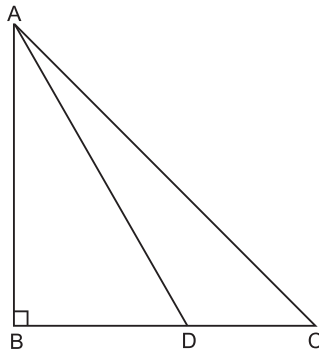

Point D is mid-point of BC,

36. $AC^2 =$
 (a) $AD^2 + CD^2$ (b) $AB^2 + 4BD^2$
 (c) $BD^2 + CD^2$ (d) $AD^2 + BD^2$
37. $AD^2 =$
 (a) $AB^2 + BD^2$ (b) $BD^2 - AB^2$
 (c) $4AB^2$ (d) $3CB^2$
38. $AC^2 =$
 (a) $AD^2 - 3AB^2$ (b) $4AD^2 - AB^2$
 (c) $4AD^2 - 3AB^2$ (d) $4AD^2 + 3AB^2$
39. $BC =$
 (a) BD (b) CD
 (c) $2BD$ (d) $4BD$
40. $CD^2 =$
 (a) $AB^2 - AD^2$ (b) $AD^2 - AB^2$
 (c) $AB^2 + AD^2$ (d) $2AD^2$

Answers

- | | | | | |
|---------|---------|---------|---------|---------|
| 1. (b) | 2. (c) | 3. (a) | 4. (c) | 5. (b) |
| 6. (d) | 7. (c) | 8. (d) | 9. (a) | 10. (b) |
| 11. (d) | 12. (d) | 13. (d) | 14. (d) | 15. (b) |
| 16. (d) | 17. (b) | 18. (c) | 19. (b) | 20. (c) |
| 21. (a) | 22. (d) | 23. (d) | 24. (d) | 25. (d) |
| 26. (c) | 27. (a) | 28. (d) | 29. (b) | 30. (c) |
| 31. (b) | 32. (a) | 33. (c) | 34. (a) | 35. (d) |
| 36. (b) | 37. (a) | 38. (c) | 39. (c) | 40. (b) |